



TWMA Norge



TWMA Norge AS provides the management and infrastructure necessary to ensure cradle to grave solutions for effective management of those waste streams generated when drilling any well, whether it be onshore or offshore.

Talk to the specialists

The Company

TWMA Norge AS is a Norwegian registered company providing integrated drilling waste management services to the upstream oil and gas industry.

The Integrated Waste Management service package includes the rig handling plus associated services, transport, disposal and treatment of oil based mud contaminated cuttings, oily sludges, slops and general waste generated when drilling any well, offshore or onshore.

The TWMA treatment facility is located at the Mongstad base and has been custom designed to provide state of the art TCC thermal treatment technology for the processing of drilled cuttings.

The site details are as follows:

- Located at Mongstad Base
- TCC cuttings processing
- Cuttings and Slops storage facility
- SFT licensed
- Bin washing
- Slops treatment

These facilities are combined with the necessary infrastructure required to ensure that a fully integrated drilling waste management service can be provided to clients to meet the ever

increasing standards of the industry while fully complying with the exacting HSE and operational standards expected.

These integrated waste management services may be summarised as follows:

- TCC Hydrocarbon Waste Treatment
- CCDS Cuttings Handling System
- Tank and Vessel Cleaning
- Waste Management



TCC-RotoMill Hydrocarbon Waste Treatment

The TCC-RotoMill thermal treatment plant uses a unique combination of electrical and mechanical energy to generate the temperatures required to evaporate the fluid phases of water and oil from the drilling waste. These vapours are then condensed and recovered separately allowing

both to be recycled back in to the drilling fluid. The treated solids, which are in the form of a fine dry powder, will have an oil content of less than 1%, well below the normal acceptable levels required for disposal or recycling.

- Mobile technology for use onshore or offshore
- High processing rates of up to 5 tonnes per hour
- No emissions from the process
- Small footprint
- Recovered oil is unaffected by the process and may be recycled
- Treated solids have hydrocarbon content of less than 1%
- Recovered water may be recycled
- No skipping and shipping when processing offshore

Vacuum Rated Cuttings Bins



Specifically designed to exceed the environmental and service conditions encountered during offshore operations.

Equipment Specifications Weight & Dimensions

- Specifically designed to exceed the environmental and service conditions encountered during offshore operations.
- Available in two sizes, 5.0 MT and 7.0 MT nominal capacity.
- Constructed from mild steel.
- Vacuum rated.
- Complete with Certified sling set.
- Bins Certified to DNV 2.7-1 or relevant standard
- Lockable filling hatches.
- Hatches fitted with a soft oil resistant sealing strip to prevent product leakage during transport.
- Painted finish.

Description	Dimensions/ m L x W x H	Tare Weight	Payload	Gross Weight
4.0 MT	1.900 x 1.710 x 1.282	1.0 MT	4.0 MT	5.0 MT
7.0 MT	2.300 x 1.780 x 1.260	1.230 MT	5.77 MT	7.0 MT

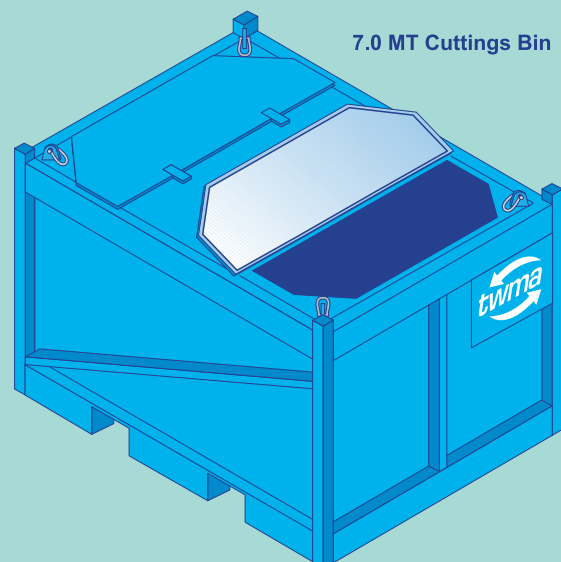
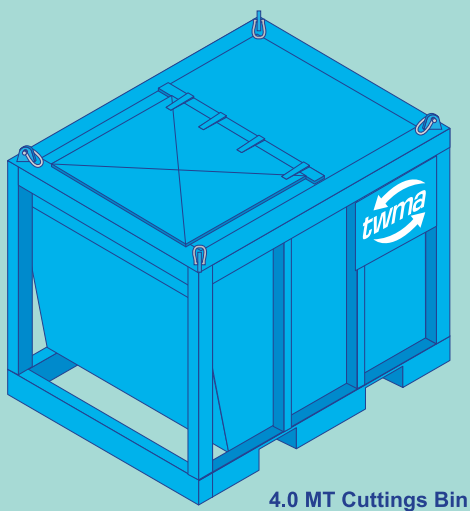

Vacuum System



The TWMA Vacuum System, designed, fabricated, installed and operated, is a constituent part of the Integrated Drilling Waste Management Solution managed and operated globally by TWMA.

Equipment Specifications Weight & Dimensions

Vacuum Unit		<p>The TWMA Vacuum unit is an integral part of the TWMA Vacuum System providing the suction capability. The system is very well proven and is found to be highly reliable working for most if not all the major oil and gas operators often in extremes of temperature and harsh operating conditions.</p>
Length	3000 mm	
Width	1820 mm	
Height	2050 mm	
Weight (Depending on Prime Mover)	4000 Kg	
Prime Mover (Electric)		
Motor	Zone 1/Category 1	
Power	75Kw/100HP	
Prime Mover (Diesel)		
Motor	Zone 2 T3/Category 2	
Power	86Kw/115HP	
Vacuum Pump		
Type	Liquid Ring	
Suction Capacity @ 500 mbar	2000 m ³ /Hr	

Vacuum Hopper		<p>The TWMA Vacuum hopper is used to receive material from the vacuum lines and drop the material into a either the TWMA CST tank, Reinjection Unit, Cuttings Driers, TCC RotoMill or Cuttings Bins.</p>
Height	2224 mm	
Width	1530 mm	
Length	1740 mm	
Tare Weight	2000 Kg	
Gross Weight	2250 Kg	

Vacuum Rated Cuttings Bins		<p>TWMA Vacuum bins are available in standard sizes as shown or custom units sizes to suit an individual contract. The bins are Vacuum rated to enable collection of material directly to the bins from the vacuum pipes. The standard bins are designed and built to comply with DNV 2.7-1.</p>
4.0 MT		
Length	1900 mm	
Width	1710 mm	
Height	1282 mm	
Tare Weight	1.00 MT	
Gross Weight	5.00 MT	
7.0 MT		
Length	2300 mm	
Width	1780 mm	
Height	1260 mm	
Tare Weight	1.23 MT	
Gross Weight	7.00 MT	

Operation

The Vacuum System can be used for all clean up situations such as separator cleaning, pit cleaning, drill floor, and vessel tank cleaning. The Vacuum system may also be used as a contingency to the primary method of transporting the Drill Cuttings from the shakers to the point of discharge.

The High powered Liquid Ring Pump gives superior

suction.

Due to small footprint and Zoned prime mover the system can operate in almost any area and environment.

The Vacuum System can collect material from around the work site and return to a combination of options:

- Due to small footprint and Zoned prime mover the units can operate in almost any area and environment.
- Return to Vacuum Hopper mounted above TWMA CST storage tanks. (CST is a Bulk transfer unit for transfer of Sludge's, Drill Cuttings and Liquids).
- Return to TCC RotoMill offshore thermal processing unit.
- Return to a Vacuum Hopper mounted above Rig tanks.(Slops tanks/Pits)
- Return to Cuttings Injection Unit.
- Return Cuttings by utilising Vacuum lids collecting material in Cuttings Bins for onward shipment.
- Flexible piping is available to suit short project durations and ease of set up and installation.
- Hard Wall piping is available to provide a long or medium term solution.
- The system can be configured to utilise a combination of all or parts of the above options.

Safety and Certification

TWMA has taken care in selecting quality components and systems to ensure a safe and user friendly system.

- Fully Guarded.
- Zone 1/Category 1 and Zone 2/ Category 2.
- Lifting Frame and Gear to DNV 2.7.-1.
- There are other certification options available on request.
- The Vacuum Unit has been designed, manufactured and tested in accordance with the standards set out for CE marking.
- Low Noise due to use of Liquid Ring Pump.
- All pipe work rated at Applicable standards.
- Drill Cuttings Skips Vacuum rated.
- Vacuum hopper Vacuum rated.
- Operators Manual
- Maintenance programme

Performance

There are many factors that can affect performance of the vacuum unit; product, hose routing, temperature are among the major factors. The following graph represents trials performed with material of particle sizes ranging from 38 mm (wet aggregate) to 1 mm (wet building sand). The results which are indicative only have been interpolated and averaged to give comparison figures.

As can be seen from the graph, the closer the waste container is to the material, the faster the transfer time.

The unit has a free air suction capacity of 2040 m³/ hour at a vacuum of 500 mbar.

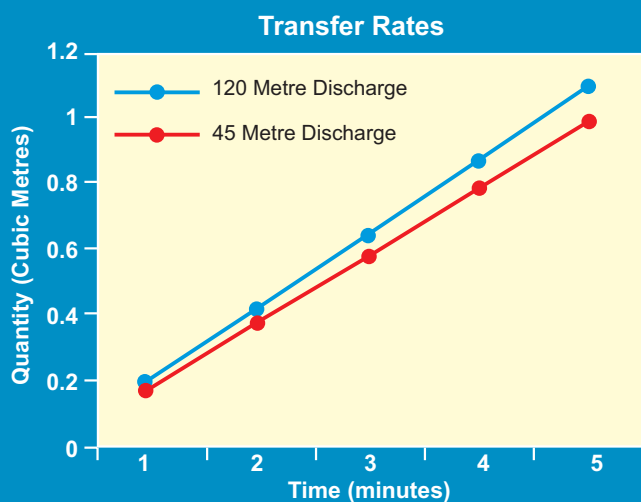

Bin Filling Station



TWMA Bin Filling Station, designed, fabricated, installed and operated, is a constituent part of the Integrated Drilling Waste Management Solution managed and operated globally by TWMA.



TWMA can design and fabricate Bin Filling Stations in a variety of configurations to suit the rig space and cuttings transfer volumes required.

Operating Detail

- Simple and quick installation (minimal rig modifications required)
- TWMA Design, Fabrication and Installation
- Industry leading TWMA Modular Bin Filling Station
- Field proven High Transfer capacity
- TWMA operated personnel
- Daily reporting systems detailing volumes of waste
- End of well reporting

Safety and Certification

- TWMA has taken care in selecting quality components and systems to ensure a safe and user friendly system
- Fully guarded
- Manufactured in accordance with CE regulations where applicable
- Emergency cut off features
- Trained operators
- Operations manual

CCDS Drilled Cuttings Handling



The CCDS system has been designed to provide the industry with a fully integrated method of transferring cuttings from the rig's shale shakers to the point of disposal. The system which uses a purpose built duplex pump at its core, provides all the necessary components to ensure the safe and efficient movement of cuttings without any interruption to drilling operations. With the CCDS system cuttings can be transferred in purpose built cuttings bins or in bulk to onshore processing facilities or directly to other offshore disposal options which may include either TCC-RotoMill processing or cuttings reinjection.

- Cuttings can be moved in bulk to onshore or offshore processing facilities
- Simple & quick installation
- Safe with minimal crane lifts
- Field proven pumps specifically designed for drilled cuttings
- High pumping capacity
- Highly flexible and adaptable
- Small footprint

Waste Management

Waste management is a costly activity for any business and the oil and gas industry is no exception. Environmental legislation has become increasingly intricate and waste issues facing the producer have become evermore complex.

TWMA is able to bring the necessary expertise and experience gained over a number of years to thoroughly evaluate and quantify the issues concerned before developing a comprehensive and sound environmental waste strategy for its clients going forward.

These may be summarised as follows:

- Segregation into defined waste recycling/reuse/disposal streams
- Recycling of all suitable materials
- Disposal - normally to licenced landfill
- Waste minimisation audits
- Compliance audits
- Development of integrated waste management strategies and programmes
- Training of operating personnel

Tank and Vessel Cleaning

TWMA Norge can provide a full tank and vessel cleaning package to the Oil and Gas industry. The service includes trained and competent personnel and equipment operating to European HSE standards for tank and vessel cleaning.

The equipment employed includes a high pressure Jetting Unit for breaking up settled material and cleaning of tank walls, Vacuum Transfer System for lifting material from tank

bottoms, Tank Entry Equipment including Tripod Hoists, Escape Sets and Gas Monitors.

- HSE training, systems and procedures
- High Pressure Jetting Unit
- Vacuum Transfer System
- Safety Unit Container



TWMA Norge AS

Mongstad Sør
5954 Mongstad
Norway

Tel: +47 56343130

Fax: +47 56343131

Email: norge@twma.co.uk

TWMA Norge a sister company to Total Waste Management Alliance PLC, a UK based company providing an equivalent range of services to the upstream oil and gas industry in the UK sector of the North Sea and elsewhere. In the UK the company has been contracted to most of the major operators drilling in the country and these have included BP, Shell, Total, ExxonMobil and many others.

UK

Head Office - TWMA Ltd
Broadfold Road
Bridge of Don
Aberdeen
AB23 8EE, UK

Tel: +44 (0) 1224 222520
Fax: +44 (0) 1224 222589
Email: sales@twma.co.uk

Norway

TWMA Norge AS
Mongstad Sør
5954 Mongstad
Norway

Tel: +47 (0) 56343130
Fax: +47 (0) 56343131

TWMA Ltd
Vatster Gott
Shetland
ZE2 9SG, UK

Tel: +44 (0) 1595 840431
Fax: +44 (0) 1595 840703

Nigeria

TWMNL
Plot F4B Bayelsa Road
GRA Phase 111
Port Harcourt
Nigeria

Tel: +234 (0) 84 232208
Fax: +234 (0) 84 231724

TWMA Ltd
Unit 12
Dales Industrial Estate
Peterhead
AB42 3JR, UK

Tel: +44 (0) 1779 472604
Fax: +44 (0) 1779 470268

Libya

TWMA Libya
Unit 27, Building 6, 7th Floor
Model 1 Form B
Souk Atholatha Ashmali
Tripoli, Libya

Tel: +218 (0) 2133 70552
Fax: +218 (0) 2172 58770

Egypt

TWMA Egypt (Oil Services) S.A.E.
64 Street 13
Port-Saeid Square
Maadi
Cairo, Egypt

Tel: +20 (0) 22 380 0759
Fax: +20 (0) 22 380 0759

Malaysia

TWMA Malaysia SDN. BHD. (835168)
Menara Maxis Tower, 36th Floor
Kuala Lumpur City Centre
Kuala Lumpur
50088, Malaysia

Tel: +60 326 150026
Fax: +60 326 150088

USA

TWMA Inc
3300 S Gessner Road
Suite 117
Houston
Texas, 77063

Tel: +1 713 782 1429
Fax: +1 713 534 1417